

microcilindri ISO 6432

minicylinders ISO 6432



- Conformi alla norma ISO 6432
Compliant to norm ISO 6432
- Grande affidabilità e lunga durata
High reliability and long life time
- Versione a doppio effetto, magnetica o non magnetica
Magnetic or non-magnetic double acting version
- Versione a semplice effetto non magnetica
Non-magnetic single acting version
- Esecuzioni speciali a richiesta
Special versions on request



Forze di ritorno della molla per cilindri a semplice effetto

Return spring forces for single acting cylinders

alesaggio <i>bore</i>	forza di ritorno della molla <i>return spring force</i>			stato della molla <i>spring status</i>
	corsa 10 [stroke]	corsa 25 [stroke]	corsa 50 [stroke]	
10	4.1 N	3.5 N	2.6 N	a riposo [at rest]
	4.5 N	4.5 N	4.5 N	compressa [compressed]
12	5.5 N	4.8 N	3.5 N	a riposo [at rest]
	6 N	6 N	6 N	compressa [compressed]
16	16.5 N	13.7 N	9 N	a riposo [at rest]
	18.3 N	18.3 N	18.3 N	compressa [compressed]
20	19 N	15.5 N	9.5 N	a riposo [at rest]
	21.5 N	21.5 N	21.5 N	compressa [compressed]
25	27 N	24 N	13.5 N	a riposo [at rest]
	29 N	29 N	29 N	compressa [compressed]

Materiali

Camicia: INOX

Stelo: INOX

Testate: alluminio anodizzato

Guarnizioni: NBR o VITON

Magnete: plastroferrite (non adatto per temperature oltre +60°C)

Materials

Barrel: stainless steel

Piston-rod: stainless steel

End-cups: aluminium (anodize treatment)

Sealings: NBR or VITON

Magnet: magnetic iron compound (not suitable for temperatures over +60°C)

Pressione di esercizio <i>Working pressure</i>	max 10 bar max 1 MPa
Temperatura di esercizio <i>Temperature range</i>	max +60°C
Alesaggi <i>Bores</i>	10; 12; 16; 20; 25 mm
Corse <i>Strokes</i>	10 ... 320 mm
Paracolpi meccanici <i>Mechanical cushioning</i>	Standard su tutta la gamma <i>Standard on the whole range</i>
Ammortizzo pneumatico <i>Pneumatic cushioning</i>	Disponibile per alesaggio 20 e 25 <i>Available for bore 20 and 25</i>
Fluido <i>Fluid</i>	Aria filtrata 50µ con o senza lubrificazione <i>50µ filtered, lubricated or non lubricated air</i>



chiave di codifica

key to codes

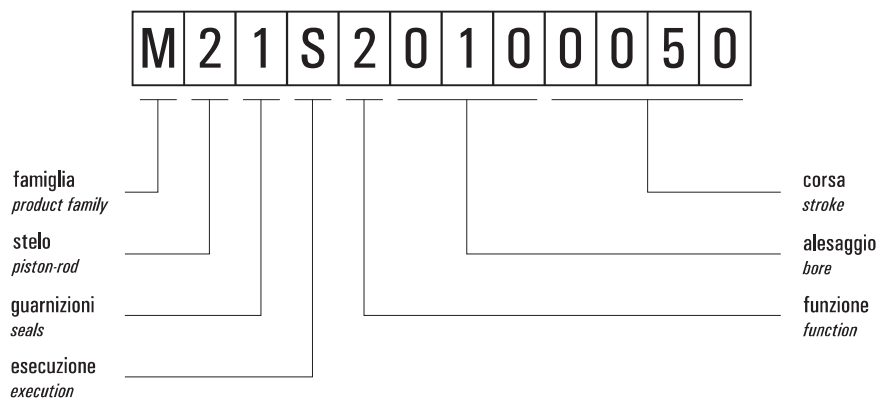

Famiglia *[product family]*

M microcilindri ISO 6432 *[minicylinders ISO 6432]*

Stelo *[piston-rod]*

2 INOX *[stainless steel]*

Guarnizioni *[seals]*

1 NBR

2 VITON

Esecuzione *[execution]*

S non magnetico *[non-magnetic]*

M magnetico *[magnetic]*

A non magnetico predisposto per bloccastelo *[non-magnetic with rod lock adaptor]*

B magnetico predisposto per bloccastelo *[magnetic with rod lock adaptor]*

Funzione *[function]*

1 semplice effetto non ammortizzato molla anteriore
[single acting front spring without pneumatic cushioning]

2 doppio effetto non ammortizzato
[double acting without pneumatic cushioning]

3 doppio effetto ammortizzato
[double acting with pneumatic cushioning]

4 doppio effetto non ammortizzato stelo passante
[double acting without pneumatic cushioning, with passing-through rod]

5 doppio effetto ammortizzato stelo passante
[double acting with pneumatic cushioning and passing-through rod]

6 semplice effetto non ammortizzato molla posteriore
[single acting back spring without pneumatic cushioning]



versioni disponibili

available versions

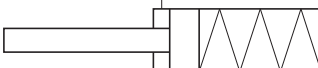
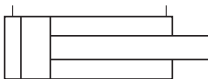
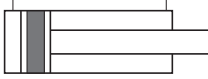
semplice effetto molla anteriore <i>single acting front spring</i> non magnetico <i>non-magnetic</i> non ammortizzato <i>without pneumatic cushioning</i>	alesaggio		10	12	16	20	25	OPZIONI <i>options</i> Lo standard è evidenziato in grigio <i>The standard is marked with grey background</i> materiale stelo [piston-rod material] INOX <i>stainless steel</i> materiale guarnizioni [seals material] NBR VITON predisposizione per bloccastelo <i>rod lock adaptor</i> non disponibile per l'alesaggio 10 <i>not available for bore 10</i>	
	corsa	bore							stroke
	10	X	X	X	X	X			
	25	X	X	X	X	X			
	50	X	X	X	X	X			
									
	10			X	X	X			
	25			X	X	X			
	50			X	X	X			
									
doppio effetto <i>double acting</i> non magnetico <i>non-magnetic</i> non ammortizzato <i>without pneumatic cushioning</i>	alesaggio		10	12	16	20	25	OPZIONI <i>options</i> Lo standard è evidenziato in grigio <i>The standard is marked with grey background</i> materiale stelo [piston-rod material] INOX <i>stainless steel</i> materiale guarnizioni [seals material] NBR VITON predisposizione per bloccastelo <i>rod lock adaptor</i> non disponibile per l'alesaggio 10 <i>not available for bore 10</i>	
	corsa	bore							stroke
		10	X	X	X	X	X		
		25	X	X	X	X	X		
		50	X	X	X	X	X		
		80	X	X	X	X	X		
		100	X	X	X	X	X		
		125	X	X	X	X	X		
		160	X	X	X	X	X		
		200	X	X	X	X	X		
	250			X	X	X			
	320			X	X	X			
									
doppio effetto <i>double acting</i> magnetico <i>magnetic</i> non ammortizzato <i>without pneumatic cushioning</i>	alesaggio		10	12	16	20	25	OPZIONI <i>options</i> Lo standard è evidenziato in grigio <i>The standard is marked with grey background</i> materiale stelo [piston-rod material] INOX <i>stainless steel</i> materiale guarnizioni [seals material] NBR VITON predisposizione per bloccastelo <i>rod lock adaptor</i> non disponibile per l'alesaggio 10 <i>not available for bore 10</i>	
	corsa	bore							stroke
		10	X	X	X	X	X		
		25	X	X	X	X	X		
		50	X	X	X	X	X		
		80	X	X	X	X	X		
		100	X	X	X	X	X		
		125	X	X	X	X	X		
		160	X	X	X	X	X		
		200	X	X	X	X	X		
	250			X	X	X			
	320			X	X	X			
									

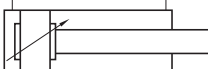
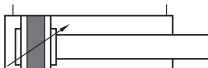
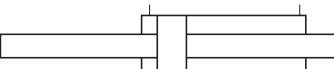

versioni disponibili available versions

doppio effetto <i>double acting</i> non magnetico <i>non-magnetic</i> ammortizzato <i>with pneumatic cushioning</i>	alesaggio		10	12	16	20	25	OPZIONI <i>options</i> Lo standard è evidenziato in grigio <i>The standard is marked with grey background</i>		
	corsa	bore							stroke	
	10								materiale stelo [piston-rod material] INOX <i>stainless steel</i> materiale guarnizioni [seals material] NBR VITON predisposizione per bloccastelo <i>rod lock adaptor</i>	
	25					X	X			
	50					X	X			
	80					X	X			
	100					X	X			
	125					X	X			
	160					X	X			
	200					X	X			
	250					X	X			
	320					X	X			
doppio effetto <i>double acting</i> magnetico <i>magnetic</i> ammortizzato <i>with pneumatic cushioning</i>	alesaggio		10	12	16	20	25	OPZIONI <i>options</i> Lo standard è evidenziato in grigio <i>The standard is marked with grey background</i>		
	corsa	bore							stroke	
		10								materiale stelo [piston-rod material] INOX <i>stainless steel</i> materiale guarnizioni [seals material] NBR VITON predisposizione per bloccastelo <i>rod lock adaptor</i>
		25				X	X		X	
		50				X	X		X	
		80				X	X		X	
		100				X	X		X	
		125				X	X		X	
		160				X	X		X	
		200				X	X		X	
250					X	X	X			
320					X	X	X			
doppio effetto <i>double acting</i> non magnetico <i>non-magnetic</i> non ammortizzato <i>without pneumatic cushioning</i> stelo passante <i>passing-through rod</i>	alesaggio		10	12	16	20	25	OPZIONI <i>options</i> Lo standard è evidenziato in grigio <i>The standard is marked with grey background</i>		
	corsa	bore							stroke	
		10				X	X		X	materiale stelo [piston-rod material] INOX <i>stainless steel</i> materiale guarnizioni [seals material] NBR VITON predisposizione per bloccastelo <i>rod lock adaptor</i>
		25				X	X		X	
		50				X	X		X	
		80				X	X		X	
		100				X	X		X	
		125				X	X		X	
		160				X	X		X	
		200				X	X		X	
250					X	X	X			
320					X	X	X			



versioni disponibili

available versions

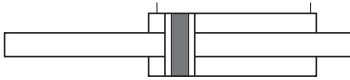
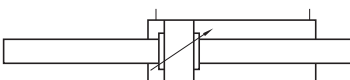
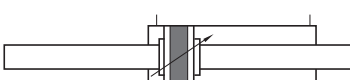
doppio effetto <i>double acting</i> magnetico <i>magnetic</i> non ammortizzato <i>without pneumatic cushioning</i> stelo passante <i>passing-through rod</i>	alesaggio		10	12	16	20	25	OPZIONI <i>options</i> Lo standard è evidenziato in grigio <i>The standard is marked with grey background</i>	
	corsa	bore							
	10				X	X	X		materiale stelo [piston-rod material] INOX <i>stainless steel</i> materiale guarnizioni [seals material] NBR VITON predisposizione per bloccastelo <i>rod lock adaptor</i>
	25				X	X	X		
	50				X	X	X		
	80				X	X	X		
	100				X	X	X		
	125				X	X	X		
	160				X	X	X		
	200				X	X	X		
	250				X	X	X		
	320				X	X	X		
doppio effetto <i>double acting</i> non magnetico <i>non-magnetic</i> ammortizzato <i>with pneumatic cushioning</i> stelo passante <i>passing-through rod</i>	alesaggio		10	12	16	20	25	OPZIONI <i>options</i> Lo standard è evidenziato in grigio <i>The standard is marked with grey background</i>	
	corsa	bore							
	10								materiale stelo [piston-rod material] INOX <i>stainless steel</i> materiale guarnizioni [seals material] NBR VITON predisposizione per bloccastelo <i>rod lock adaptor</i>
	25					X	X		
	50					X	X		
	80					X	X		
	100					X	X		
	125					X	X		
	160					X	X		
	200					X	X		
	250					X	X		
	320					X	X		
doppio effetto <i>double acting</i> magnetico <i>magnetic</i> ammortizzato <i>with pneumatic cushioning</i> stelo passante <i>passing-through rod</i>	alesaggio		10	12	16	20	25	OPZIONI <i>options</i> Lo standard è evidenziato in grigio <i>The standard is marked with grey background</i>	
	corsa	bore							
	10								materiale stelo [piston-rod material] INOX <i>stainless steel</i> materiale guarnizioni [seals material] NBR VITON predisposizione per bloccastelo <i>rod lock adaptor</i>
	25					X	X		
	50					X	X		
	80					X	X		
	100					X	X		
	125					X	X		
	160					X	X		
	200					X	X		
	250					X	X		
	320					X	X		

microcilindri ISO 6432

minicylinders ISO 6432

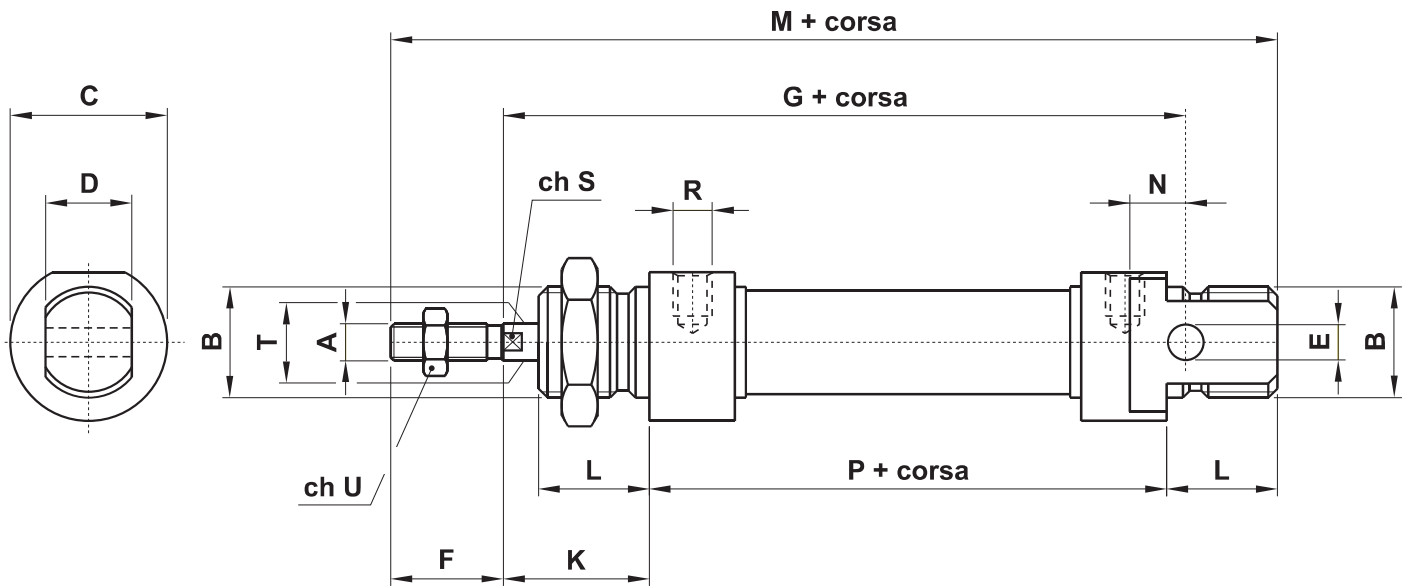

∅	A	B	C	D	E	F	G	K	L	M	N	P	R	S	T	U
10	M4	M12x1.25	∅16	8	∅4	12	64	16	12	86	6	46	M5	-	∅4	7
12	M6	M16x1.5	∅19	12	∅6	16	75	22	18	104	9	48	M5	5	∅6	10
16	M6	M16x1.5	∅19	12	∅6	16	82	22	18	109	9	53	M5	5	∅6	10
20	M8	M22x1.5	∅27	16	∅8	20	95	24	20	131	12	67	G1/8"	7	∅8	13
25	M10x1.25	M22x1.5	∅30	16	∅8	22	104	28	22	140	12	68	G1/8"	9	∅10	17

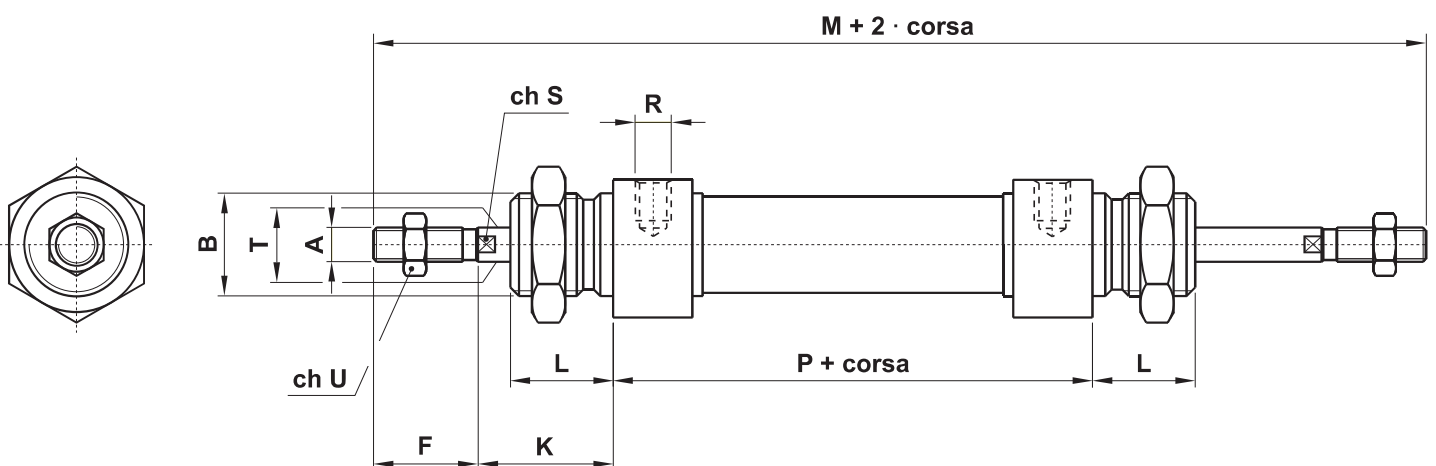

∅	A	B	F	K	L	M	P	R	S	T	U
16	M6	M16x1.5	16	22	18	129	53	M5	5	∅6	10
20	M8	M22x1.5	20	24	20	155	67	G1/8"	7	∅8	13
25	M10x1.25	M22x1.5	22	28	22	168	68	G1/8"	9	∅10	17

microcilindri ISO 6432

minicylinders ISO 6432



SEMPLICE EFFETTO MOLLA POSTERIORE

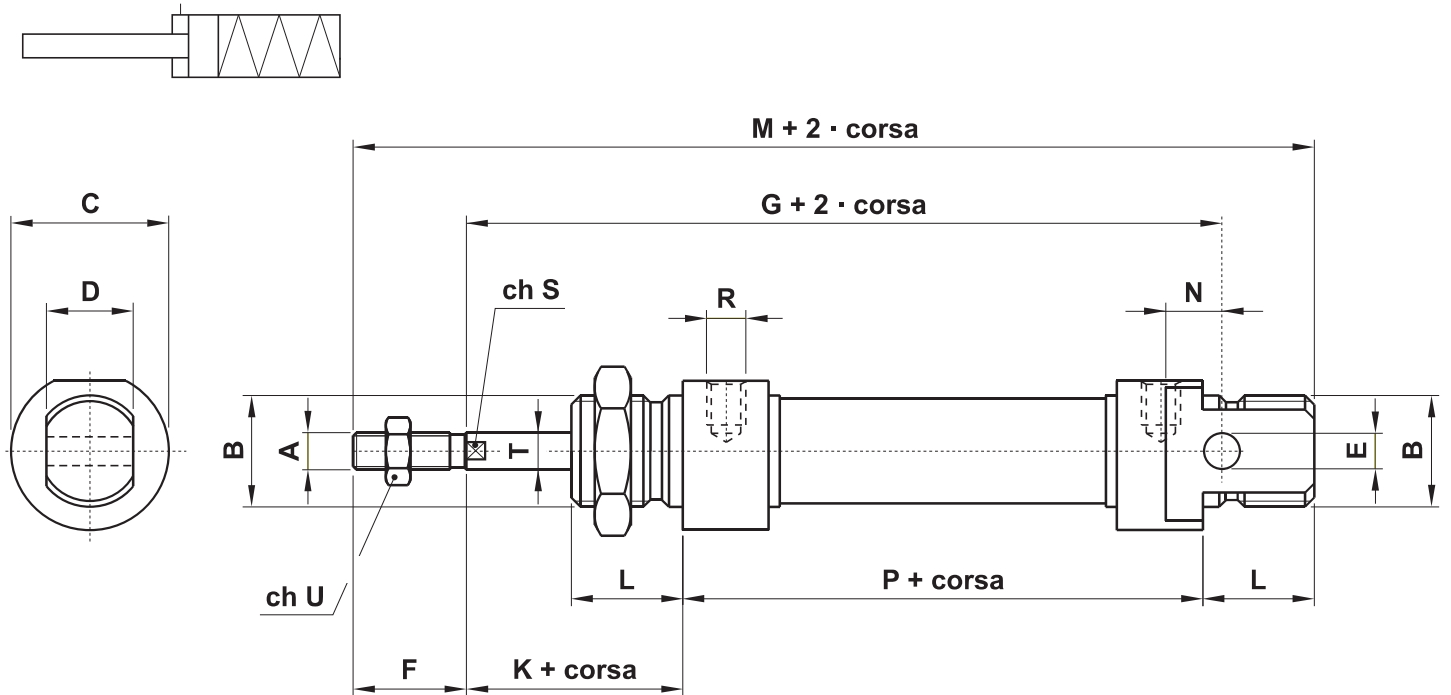

∅	A	B	C	D	E	F	G	K	L	M	N	P	R	S	T	U
16	M6	M16x1.5	∅19	12	∅6	16	107.5	22	18	134.5	9	78.5	M5	5	∅6	10
20	M8	M22x1.5	∅27	16	∅8	20	118	24	20	154	12	90	G1/8"	7	∅8	13
25	M10x1.25	M22x1.5	∅30	16	∅8	22	130	28	22	166	12	94	G1/8"	9	∅10	17

6

fissaggi per microcilindri ISO 6432

fixing elements for minicylinders ISO 6432



PIEDINO

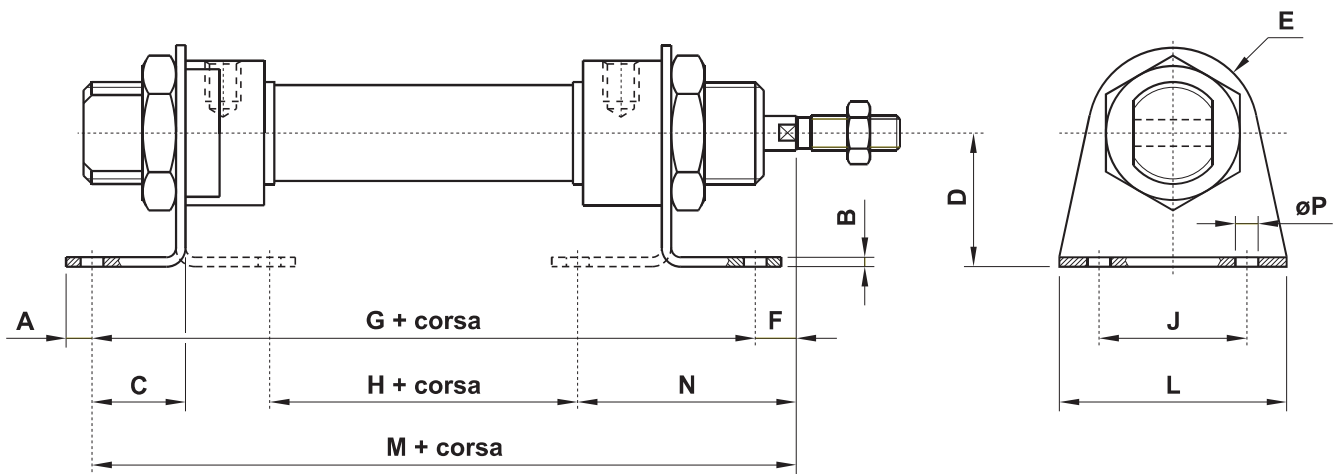

ϕ	A	B	C	D	E	F	G	H	J	L	M	N	P
10	5	3	11	16	10	5	68	30	25	32	73	24	4.5
12	6	4	14	20	12.5	8	76	28	32	42	84	32	5.5
16	6	4	14	20	12.5	8	81	33	32	42	89	32	5.5
20	8	5	17	25	20	7	101	43	40	54	108	36	6.6
25	8	5	17	25	20	11	102	44	40	54	113	40	6.6

FLANGIA

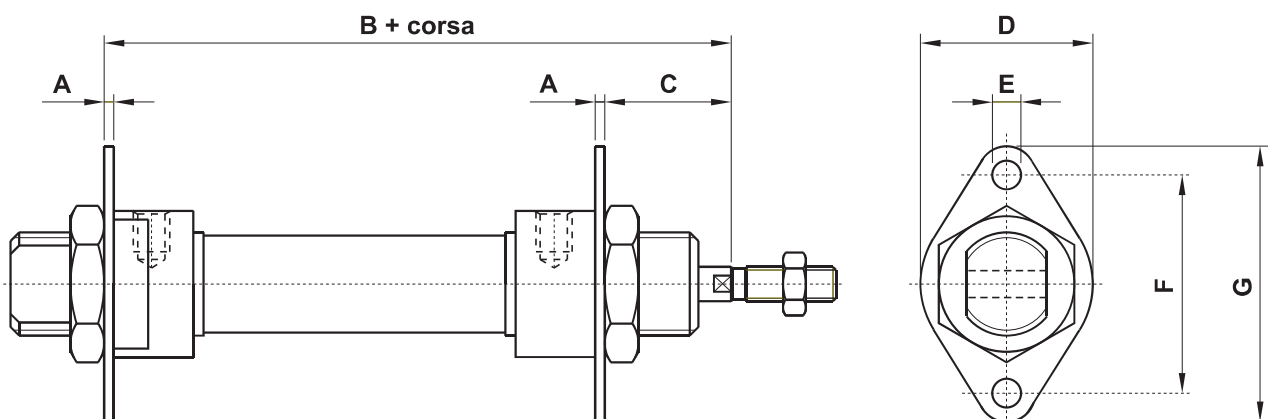

ϕ	A	B	C	D	E	F	G
10	3	65	13	22	$\phi 4.5$	30	40
12	4	74	18	30	$\phi 5.5$	40	52
16	4	79	18	30	$\phi 5.5$	40	52
20	5	96	19	40	$\phi 6.6$	50	66
25	5	101	23	40	$\phi 6.6$	50	66

fissaggi per microcilindri ISO 6432

fixing elements for minicylinders ISO 6432



CONTROCERNIERA CON PERNO

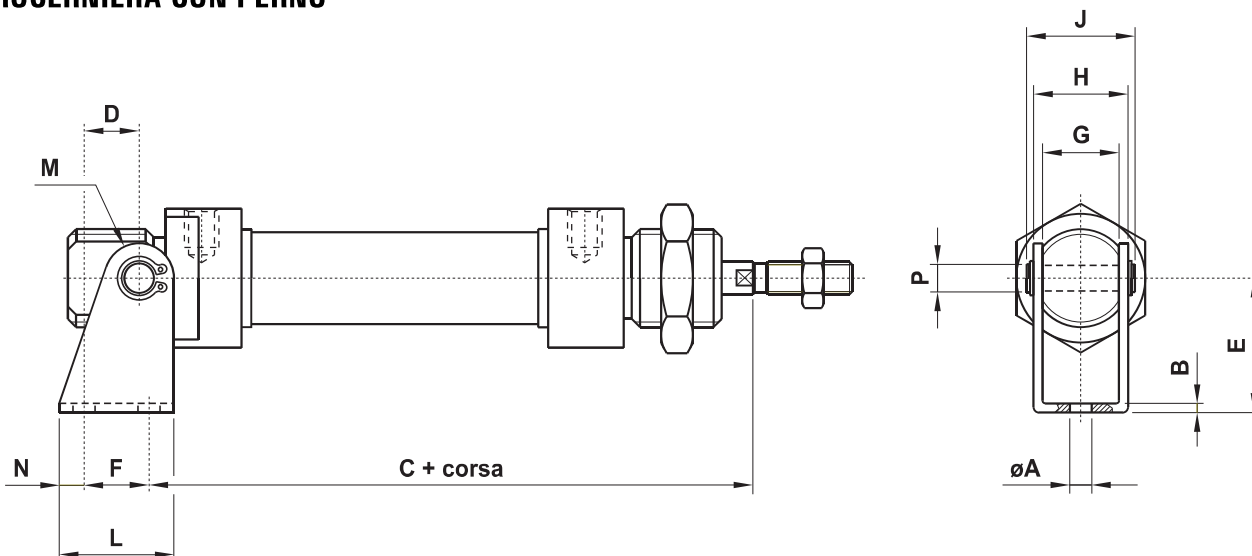

ø	A	B	C	D	E	F	G	H	J	L	M	N	P
10	4.5	2.5	62.5	12.25	24	12.5	8.1	13	17	20	5	4.75	ø4
12	5.5	3	73	13	27	15	12.1	18	23	25	7	5	ø6
16	5.5	3	80	13	27	15	12.1	18	23	25	7	5	ø6
20	6.6	4	91	16	30	20	16.1	24	29.5	32	10	6	ø8
25	6.6	4	100	16	30	20	16.1	24	29.5	32	10	6	ø8

DADO PER TESTATA

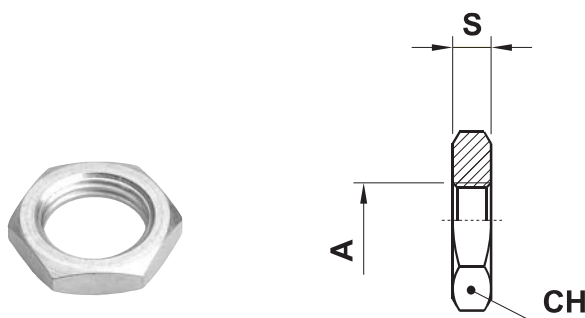

sigla part number	per alesaggio for bore	A	CH	S
GPM010	10	M12x1.25	19	7
GPM12-16	12-16	M16x1.5	22	6
GPM20-25	20-25	M22x1.5	27	8

PIEDINO

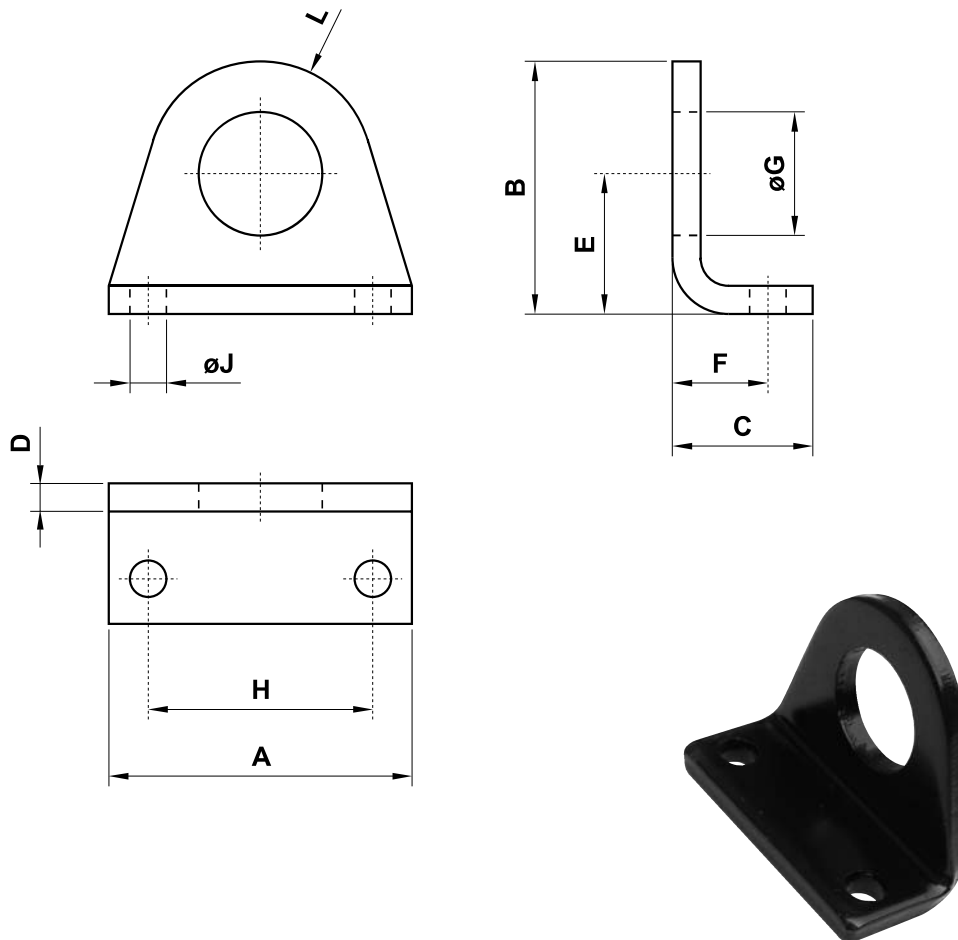

sigla* part number*	per alesaggio for bore	A	B	C	D	E	F	G	H	J	L
PDMC08-10	8-10	35	26	16	3	16	11	12	25	4.5	10
PDMC12-16	12-16	42	32.5	20	4	20	14	16	32	5.5	12.5
PDMC20-25	20-25	54	45	25	5	25	17	22	40	6.6	20

* La sigla si riferisce a un solo piedino e non alla coppia

* The part number is referred to only one element and not to the couple

FLANGIA

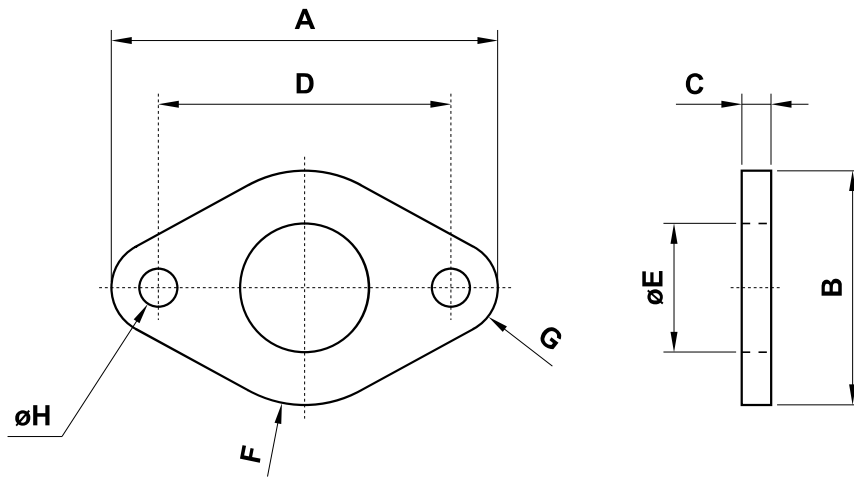

6

sigla part number	per alesaggio for bore	A	B	C	D	E	F	G	H
FLMC08-10	8-10	40	22	3	30	12	11	5	4.5
FLMC12-16	12-16	52	30	4	40	16	15	6	5.5
FLMC20-25	20-25	66	40	5	50	22	20	8	6.6

CONTROCERNIERA CON PERNO

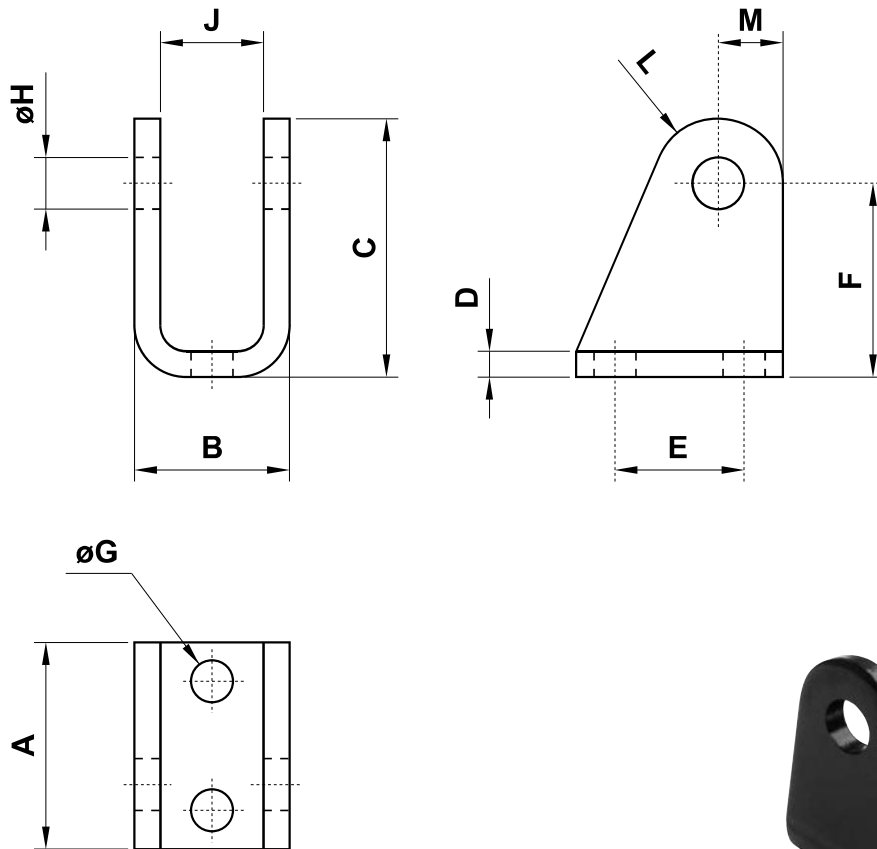

sigla part number	per alesaggio for bore	A	B	C	D	E	F	G	H	J	L	M
CCMC08-10	8-10	20	13	29	2.5	12.5	24	4.5	4	8.1	5	5
CCMC12-16	12-16	25	18	34	3	15	27	5.5	6	12.1	7	7
CCMC20-25	20-25	32	24	40	4	20	30	6.6	8	16.1	10	10